

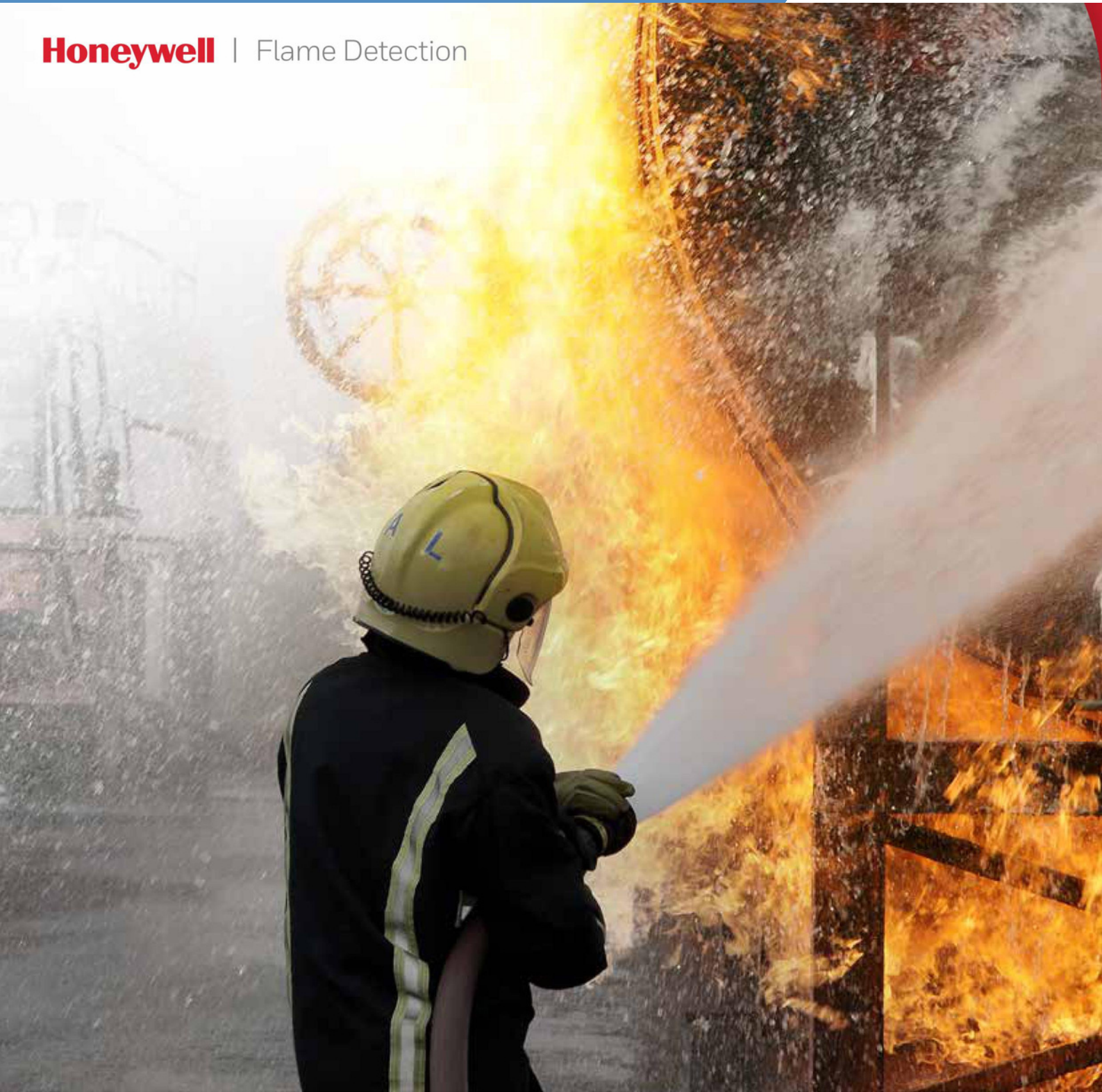

**Honeywell** | Flame Detection



## FS20X Fire and Flame Detector

Multi-Spectrum UV/Dual IR/VIS Fire and Flame Detector

[www.honeywell-indonesia.com](http://www.honeywell-indonesia.com)  
[www.marinemaju.com](http://www.marinemaju.com)



Marine Maju Mandiri Official Store

tokopedia

LTC-Glodok Lt. 1 Blok B17 No. 1-3  
Jl. Hayam Wuruk No. 127, Taman Sari,  
Jakarta Barat, DKI Jakarta, Indonesia



## FS20X Detector

The FS20X is the latest generation high technology Multi Spectrum (UV/Dual IR/VIS) Fire and Flame Detector, which is part of the FSX family of advanced technology Electro-Optical Flame detectors.

Based on the foundation of the highly successful and reliable SS4 detector, the FS20X detector represents a quantum leap in integrating Infrared and Ultraviolet sensing technologies. The FS20X is a Multi-Spectrum and UV/Dual IR/VIS fire and flame detector with a proven UV solar-blind sensor. The FS20X exhibits faster false-alarm free response to fires over a wider temperature range and with a much longer detection range compared to conventional UV/IR detectors.



Conventional and older technology UV/IR detectors, using narrow band 4.3 micron IR sensors, will not respond to smoky fires or if the detector lens is contaminated with oil and other substances since both UV and 4.3 micron signals are attenuated, obscured or absorbed by thick smoke or detector lens contaminations. All UV sensors will be attenuated to some degree. Also, these old technology UV/IR detectors will not alarm to any fire if they are installed behind ordinary window glass.

Dual microprocessors provide a high level of fail-safe operation combined with fast and reliable performance. The master microprocessor performs high-speed digital sampling and signal processing calculations whilst the slave microprocessor handles various sensor data, performs communications, self-diagnostics and provides interface versatility and additional memory for storing event log and FirePic™ data. The FS20X detector has a detection range in excess of 60 m (200 feet) (very high sensitivity setting) for the detection of a 0.1m<sup>2</sup> (one square-foot) Heptane reference fire and has a cone of vision greater in volumetric coverage than most UV/IR detectors. This means fewer detectors can be used as compared to other manufacturers' detectors.

The FS20 detector using advanced patented algorithms for signal processing and fire and flame analysis is designed to alarm to all types of fires in all industrial environmental conditions. If the detector's UV signal is degraded due to heavy smoke or a contaminated lens, the FS20X's patented WideBand IR™, Near Band IR and Visible sensors will still alarm to fire, albeit at a reduced sensitivity and slower response time.

GENERAL DIMENSIONS  
Side and Back Views  
(All Dimensions in mm)

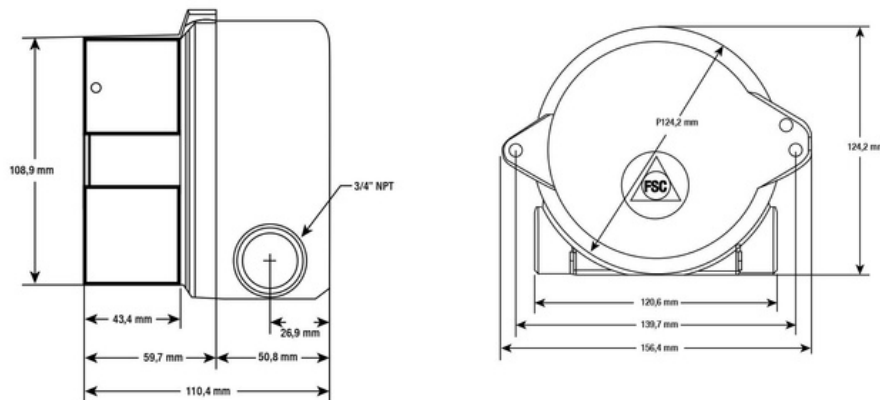





## General Specification

GENERAL SPECIFICATIONS	
FIELD OF VIEW	90° Horizontal Cone of vision, ± 45° from on axis
SENSITIVITY	Very high (60m), high (45m), medium (30m) and low (15m) - switch selectable
RESPONSE TIME	3-5 Seconds to 0.1 m <sup>2</sup> (1 sq. ft.) n-Heptane fire at 30 m (100 ft.) 3-10 Seconds to 0.1 m <sup>2</sup> (1 sq. ft.) n-Heptane fire at 60 m (200 ft.)
SPECTRAL SENSITIVITY	Ultraviolet: 185 - 260 nanometres Visible: 400 - 700 nanometres Near Band IR: 0.7 - 1.1 microns Wide Band IR: 1.1 - 3.5 microns
OPERATING VOLTAGE	24 Vdc nominal (18-32 Vdc) - regulated
POWER CONSUMPTION	Operating: 85 mA @ 24 Vdc nominal
ALARM	135 mA @ 24 Vdc nominal
HEATER	155 mA - additional Note: Heater will turn on at -17°C (0°F)
OUTPUT RELAYS	Fire Alarm: SPDT (NO / NC) - De-energised/energised, latching/non-latching Fault: SPST (NO) - De-energised/energised, latching/non-latching Auxiliary: SPDT (NO / NC) - De-energised/energised, latching/non-latching Contacts rating: 1 amp @ 24 Vdc
ANALOG OUTPUT	0 - 20 mA stepped - source or sink user selectable
LOOP RESISTANCE	50 - 400 Ohms
COMMUNICATION	One of the following - user selectable: • RS-485, ModBus Protocol • RS-485, FireBus II • RS-485 Special (optional) • HART, Optional plug-in module (not available on EN54-10 units)
VISUAL INDICATORS	Green LED: Power Red LED: Alarm Yellow LED: Fault
TEMPERATURE RANGE	Operating: -40 to +85°C (-40 to +185°F) Storage: -55 to +110°C (-67 to +230°F)
HUMIDITY RANGE	5 to 98% relative humidity, non-condensing
VIBRATION	Meets or exceeds MilSpec 810C Method 514.2, Curve AW12
WIRING	2.5 mm <sup>2</sup> (14 AWG) to 0.326 mm <sup>2</sup> (22 AWG); shielded cable recommended
CONDUIT ENTRIES	Standard: Two M25 or two ¾" NPT
ENCLOSURE MATERIALS	Copper-free powder coated aluminum or 316 stainless steel
ENCLOSURE TYPE	4X, IP66 and NEMA 4
CERTIFICATIONS	<b>FM:</b> Class I, Div. 1 & 2, Groups B, C, & D; Class II, Div. 1 & 2, Groups E, F, & G; Class III <b>ATEX/IECEX:</b> Ⓜ II 2 G Ex db IIC T4 (Ta: -40 to +110°C), T5 (Ta: -40 to +75°C), T6 (Ta: -60 to +60°C), II 2 D Ex tb IIIC T135°C Ⓜ II 2 G Ex db IIC T4 (Ta: -60 to +110°C), T5 (Ta: -60 to +75°C), T6 (Ta: -60 to +60°C), II 2 D Ex tb IIIC T135°C <b>CE</b> Complies with EN6100-6-4 & EN50130-4 <b>INMETRO</b> <b>CU-TR</b> <b>China-EX</b> <b>SIL Rating:</b> FMEDA available on request <b>EN54-10:</b> FS20X certified 1175a/01 (LPCB); CPR 0832-CPR-F0515
SHIPPING WEIGHT	Aluminum: 1.6 kg (3.6 lbs) Stainless Steel: 3.2 kg (7 lbs)
MOUNTING	Swivel bracket assembly - optional
WARRANTY	Three years from date of shipping

### FEATURES

- Patented WideBand IR™ Infrared combined with Ultraviolet
- Detection range greater than 60 m (200 feet) to 0.1 m<sup>2</sup> (1 sq. ft.) heptane fire
- Patented Electronic Frequency Analysis
- Visible sensor for optimum false alarm rejection
- Selectable detection sensitivities
- Solar blind 90° cone-of-vision
- Dual microprocessors for reliable performance
- Real-time clock for accurate time dating of events
- FirePic™ - Up to 6 pre-fire event data storage
- Event log - Up to 200 events with date and time stamp
- Built-in RS-485 ModBus communication
- Built-in non-isolated 4-20 mA analog output (sink or source)
- Alarm, Fault and Fire Verification relays
- Automatic Optical Path and Electronic self-test
- Patented Electronics Module for component protection with plug-in terminations for easy field installation
- Two 25 mm conduit entries or two ¾" NPT
- Low power consumption
- High RFI and EMI immunity
- FM hazardous area approved
- Ex d ATEX approved
- CU-TR approved
- INMETRO approved
- Meets SIL 2 requirements
- Certified to EN54-10:2002 (option)
- FM 3260 performance

### BENEFITS

- Detects hydrocarbon and non-hydrocarbon fuel fires in all environmental conditions
- Wide operating temperature range
- Arc welding immunity
- False alarm rejection
- Minimal maintenance for trouble-free operation
- PC software and interface module (FSIM) for fault diagnostics real-time graphs (RTGs), and downloading of FirePics™ and event log
- Suitable for a wide variety of applications

### APPLICATIONS

- Refineries and oil production facilities
- Off-Shore platforms
- Turbine/Compressor enclosures
- Acetylene processing and storage
- Oil and Gas pipelines and pumping stations
- LNG/LPG loading and unloading facilities
- Natural Gas and CNG plants
- Ethanol, Methanol, and IPA production and storage
- Crude oil and gasoline storage and tank farms
- Aircraft hangars
- Hydrogen plants and storage
- Paint and solvent storage
- Chemical production, storage, and loading facilities
- Power plants
- Silane gas storage

